

TECHNICAL DATA

SINGLE DRUM ROLLERS

BW 220 D-5

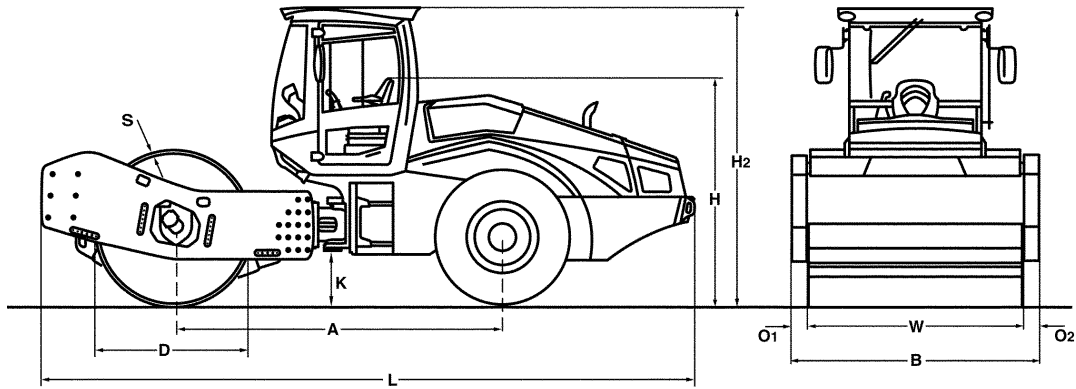



Dimensions in mm

	A	B	D	H	H2	K	L	O1	O2	S	W
BW 220 D-5	3255	2300	1600	2300	3040	495	6500	85	85	40	2130

Shipping dimensions in m3

BW 220 D-5

without ROPS

34,385

with ROPS

45,448

Machine type	Compaction output (m3/h)			
	Rock fill	Gravel, sand	Mixed soil	Silt, clay
BW 220 D-5	940-1880	700-1400	560-960	250-500

Machine type	Compacted layer thickness (m)			
	Rock fill	Gravel, sand	Mixed soil	Silt, clay
BW 220 D-5	1,40	1,00	0,70	0,30

Technical Data

BOMAG BW 220 D-5

Weights

Grossweight	kg	22.500
Operating weight CECE w. ROPS-cabin	kg	20.100
Axle load, drum CECE	kg	13.160
Axle load, wheels CECE	kg	6.940
Static linear load CECE	kg/cm	61,8

Dimensions

Working width	mm	2.130
Track radius, inner	mm	4.120

Driving Characteristics

Speed (1)	km/h	0- 4,0
Speed (2)	km/h	0- 5,0
Speed (3)	km/h	0- 6,0
Speed (4)	km/h	0- 10,0
Max. gradeability (dep. on soil con.)	%	46

Drive

Engine manufacturer		Deutz
Type		TCD 2012 L06
Emission stage		Stage IIIa / TIER3
Cooling		water
Number of cylinders		6
Performance ISO 3046	kW	150,0
Performance SAE J 1995	hp	202,0
Speed	min-1	2.200
Fuel		Diesel
Electric equipment	V	12
Drive system		hydrost.
Drum driven		standard

Drums and Tyres

Tyre size		23.1-26 12PR
-----------------	--	--------------

Brakes

Service brake		hydrost.
Parking brake		hydromec.

Steering

Steering system		oscil.artic.
Steering method		hydrost.
Steering / oscillating angle +/-	grad	35/12

Exciter system

Drive system		hydrost.
Frequency	Hz	26/31
Amplitude	mm	2,10/1,20
Centrifugal force	kN	328/266
Centrifugal force	t	33,5/27,1

Capacities

Fuel	l	280,0
------------	---	-------

Technical modifications reserved. Machines may be shown with options.

Standard Equipment

- BOMAG ECOMODE
- Self locking differential
- Rear axle with twin spring accumulator brakes
- Hydrostatic travel and vibration drive
- Hydrostatic articulated steering
- Articulated joint lock
- Seat with arm rest and adj. for position and height
- Sliding window
- Battery disconnect switch
- Single lever control for travel and vibration
- Warning, information and operation displays with LCD
- Loading mode
- Emergency STOP
- Working lights front / rear
- Back-up alarm
- Noise insulation
- 2 Scrapers
- Warning horn

Optional Equipment

- ROPS/FOPS cabin with seat belts
 - Sliding window
- Cabin with air conditioning
- Rearview camera
- Air condition
- Radio (Bluetooth)
- Pre start cabin heating
- Comfort package: Adjustable seat and adjustable steering column
- Rotary beacon
- Indicator and hazard lights
- BOMAG ECOSTOP
- ECONOMIZER
- TERRAMETER
- BOMAG TELEMATIC POWER
- Padfoot segment kit (D)
- Measuring- and machine data interface for third-party suppliers
- Reversing alarm buzzer with broad band audio
- LED Working head lights
- Protective ventilation system (Pre-installation)
- Radio preparation
- Quick refuelling system

